

Service Information



Model 580, 581, 582
Serial No. _____
Subject Addition of Belt Stopper
to Capstan Motor Ass'y.

No. NR-0038
Date 2/16/82

In order to prevent the possible coming off of the Capstan Belt from the Capstan Motor Pulley, it is recommended to install the Belt Stopper in the early production of the model 580, 581 and 582.

1. Parts for Modification

| <u>Part No.</u> | <u>Part Name</u> | <u>QTY</u> |
|-----------------|------------------|------------|
| 0C08208 | Belt Stopper | X 1 |

2. Installation Procedure.

- 2-1 Remove the Top Cover Ass'y.
- 2-2 Clean the Capstan Motor Pulley.
- 2-3 Press the Belt Stopper into the Capstan Motor Shaft.
Refer to Fig. 1 and Fig 2.
 - *Do not exert excessive force.
 - *Do not make a gap between the Capstan Motor Pulley and the Belt Stopper.
- 2-4 Put the Capstan Belt back.
- 2-5 Check "Wow and Flutter" and "Speed."
- 2-6 Assemble the Top Cover Ass'y.

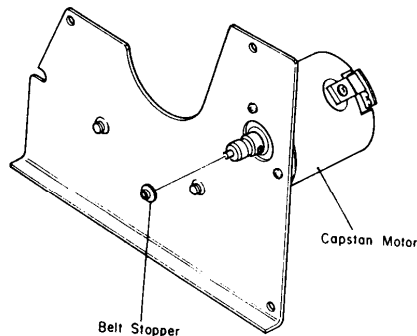

Fig. 1

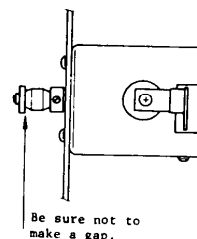

Fig. 2

The above modification is not necessary for units which have a greater serial number than the ones listed below. They have the new type motor pulley which has a front flange.

| | |
|-------|-----------|
| N-580 | A3011900 |
| N-581 | A30203310 |
| N-582 | A11102930 |