

Service Information



NAKAMICHI

Model Nakamichi 700 and 1000
Serial No. from 3709323 (700), 3107001 (1000)
Subject Adjustment Procedures for
New Type Head Base Block

No. NR-0001 (1/5)
Date 19 December 1975

1. General:

The adjustment procedures for new head block cover the machines bearing serial Nos. 3709323 and after for Nakamichi 700 and 3107001 and after for Nakamichi 1000.

Though we have already informed the adjustment procedures for new type head base block in the Nakamichi 700 service manual and service information OOD-M-0015 (1/9-9/9) for Nakamichi 1000, this explanation is revised information and it is more recommendable that you adjust new type head block according to this information.

New type head base block is head height adjustable, but the previous type required additional head spacer for head height adjustment.

Nakamichi 700---Head Mount Base (E) Ass'y CA-5168

Nakamichi 1000--Head Mount Base (D) Ass'y CA-5167

2. Adjustment Procedure:

2.1. Tape Guide Height Adjustment:

Load with care the Tape Guide Height Measurement Jig (Information Terminals, Sunnyvale California --Model Number M300).

Refer to the Fig.1, and adjust the tape guide height adjusting screw A so that the tape guide is fixed to the jig.

One turning for one time (one rotation) becomes 0.45mm tape guide height movement.

2.2. Head Height Adjustment by Track Viewer:

(1) Load the Track Viewer (DA09012A), and check the positions of playback and record heads. While adjustment, check to insure that the L-R center of each head coincides in position with the middle point between two lines (0.3mm distance) on the Track Viewer.

(2) If the L-R center deviates from the middle point, correct the head height deviation by adjusting screws E and F, together with adjusting C and D for correcting head azimuth.

Service Information



NAKAMICHI

Model _____

Serial No. from _____

Subject _____

No. NR-0001 (2/5)
Date _____

2.3. Tape Travelling Check:

Load the Tape Travelling Cassette (DA09011A), and set the playback mode. Check to insure that the tape height while running is within $\pm 0.3\text{mm}$ at any tape position when measured from the center of a cassette housing.

Note: Observing tape travelling on the playback head, check the following points:

- (1) Tape travelling does not wave.
- (2) At a tape starting point, the tolerance of tape travelling fluctuation is within about $\pm 0.3\text{mm}$.

If not, adjust the pressure roller height by adjusting screw B located at the take-up reel side. After the tape travel is corrected, check to insure that the pressure roller position is within $\pm 1\text{mm}$ when measured from the center of a cassette housing. Note that in most cases of playback head adjustment turning of the screw B will not be required for misalignment.

If tape travel cannot still be adjusted, refer to the "Tape Travelling Adjustment" on the Service Manuals.

2.4. Playback Head Track Alignment (Playback Head Height Alignment):

Load the Track Alignment Tape (DA09007A) and check the head height on the cassette tape deck. Set the Monitor SW. to Tape and play the tape back.

Adjust the playback head height screw E until each level meter of both channels reads the minimum value.

Service Information



NAKAMICHI

Model _____

Serial No. from _____

Subject _____

No. NR-0001 (3/5)
Date _____

2.5. Playback Head Azimuth Alignment:

- (1) Load the 15KHz Azimuth Tape (DA09004A) for adjusting the P.B. head azimuth. Set the Monitor SW. to the Tape position and playback. Adjust the P.B. head azimuth alignment screw C until each level meter of both channels reads the maximum value.
- (2) After completion of the adjustment in this step, check the item 2.4 Playback Head Track Alignment then recheck Playback Head Azimuth.

2.6. Record Head Height Alignment:

- (1) Load the Reference CrO2 Tape (DA09009A), set the Test Tone SW. to On position, the Tape Selector SW. to the Tape position. Set to record mode and adjust record head azimuth alignment screw D until the alignment beacon started flickering alternately.
- (2) Aligning Step (1) as above, align the screw F to obtain maximum reading of both channels.
- (3) Check to insure the following.
 - a. Record the same portion of the both A and B sides of the tape after record head azimuth is aligned.
 - b. Immerse the recorded tape into a magnetized developing solution. In turn, check to insure that the recording head tracks across the center are separated by space of 0.4 to 0.6mm typically 0.5mm as illustrated in the Fig.2.

Note: Liquid for tape magnetized development:

MAGNA-SEE, SOUND CRAFT a product of CBS RECORDS.

After development, clean the tape otherwise pressure roller will become dirty.

Service Information



NAKAMICHI

Model _____
Serial No. from _____

NR-0001

No. _____ (4/5)

Subject _____

Date _____

2.7. Head Height Check by Tack Viewer:

- (1) Load the Track Viewer again and check to insure whether the deviation from the L-R center is within 0.2mm.
- (2) If the deviation is more than 0.2mm, tape travelling will be defective such as defective head contact, pressure roller, capstan, etc.

Check to insure "2.3 Tape Travelling Check".

2.8. Apply a drip of lock tight paint to the A, B, E and F.

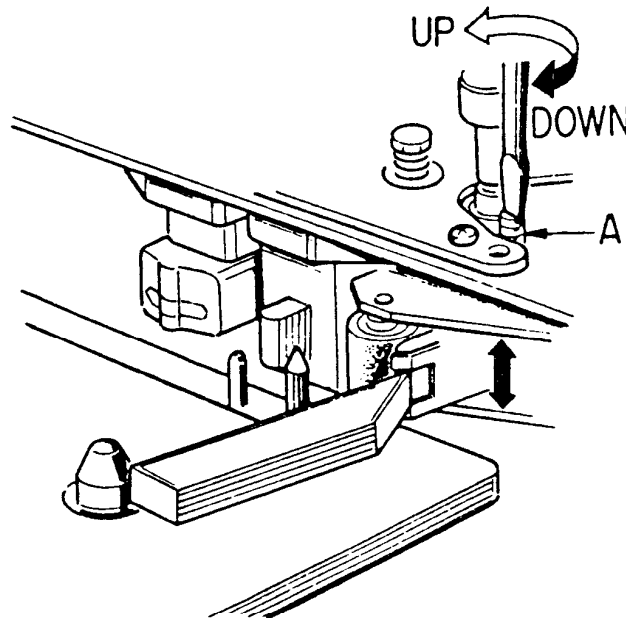

Fig.1

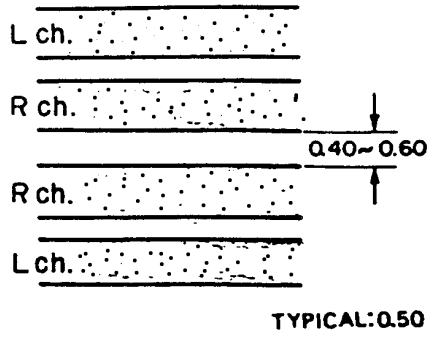

Fig. 2

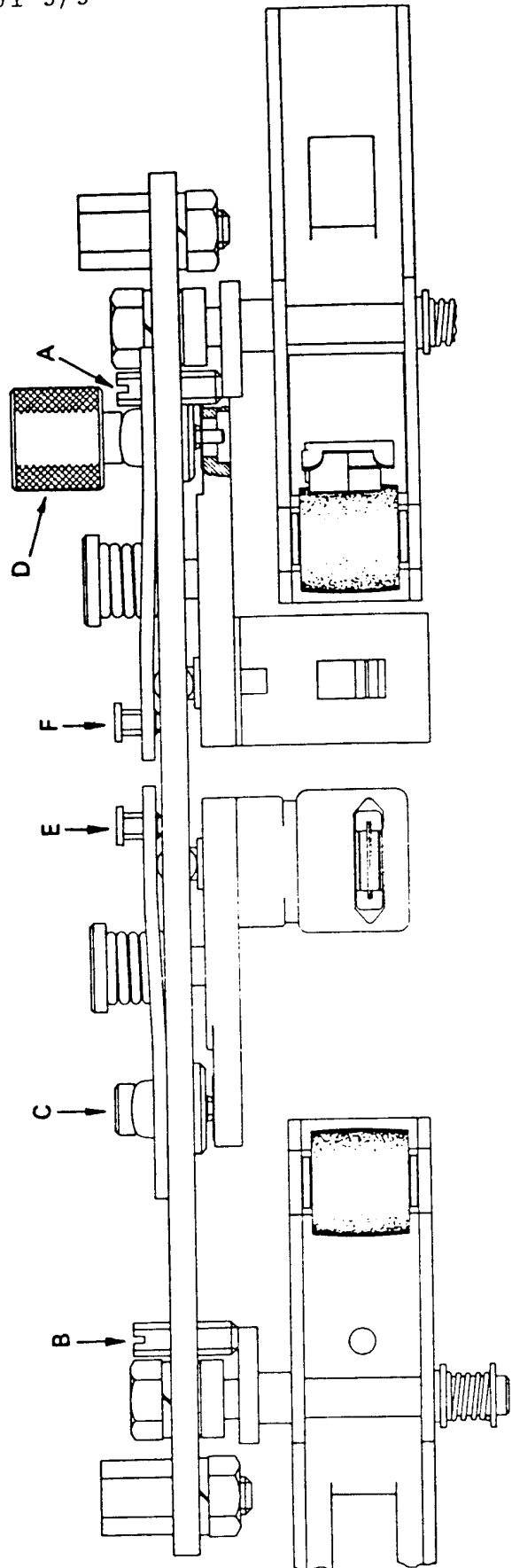

Fig. 3 New Head Base Block Assembly